

Method OIV-MA-AS311-05

Type II method

Determination of the deuterium distribution in ethanol derived from fermentation of grape musts, concentrated grape musts, grape sugar (rectified concentrated grape musts) and wines by application of nuclear magnetic resonance (SNIF-NMR/ RMN-FINS ¹)
(Oeno 426-2011)

1. Introduction

The deuterium contained in the sugars and the water in grape must is redistributed after fermentation in molecules I, II, III and IV of the wine:

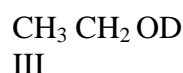

2. Scope

The method enables measurement of the Deuterium isotope ratios (D/H) in wine ethanol and ethanol obtained by fermentation of products of the vine (musts, concentrated musts, rectified concentrated musts).

3. Definitions

(D/H)_I : Isotope ratio associated with molecule I

(D/H)_{II} : Isotope ratio associated with molecule II

(D/H)_W^Q : Isotope ratio of the water in the wine (or in fermented products)

$$R = 2(\text{D/H})_{\text{II}}/(\text{D/H})_{\text{I}}$$

¹ Fractionnement Isotopique Naturel Spécifique étudié par Résonance Magnétique Nucléaire (Site Specific Natural Isotope Fractionation studied by Nuclear Magnetic Resonance). Brevet: France, 8122710; Europe, 824022099; Etats Unis, 854550082; Japon 57123249.

R expresses the relative distribution of deuterium in molecules I and II; R is measured directly from the intensities h (peak heights) of the signals and then $R = 3h_{II}/h_I$.

4. Principle

The above defined parameters R , $(D/H)_I$ and $(D/H)_{II}$ are determined by nuclear magnetic resonance of the deuterium in the ethanol extracted from the wine or from the fermentation products of the must, the concentrated must or the grape sugar (rectified concentrated must) obtained under given conditions.

5. Reagents and materials

5.1 reagents:

5.1.1 reagents for the determination of water by the Karl Fischer method (when this method is used for the measurement of the alcohol grade of the distillate).

5.1.2 Hexafluorobenzene (C_6F_6) used as lock substance

5.1.3 Trifluoroacetic acid (TFA, CAS: 76-05-1) or alternatively trifluoroacetic anhydride (TFAA, CAS: 407-25-0)

5.2 Reference Materials (available from the Institute for Reference Materials and Measurements IRMM in Geel (B)):

5.2.1 Sealed NMR tubes CRM-123, used to check the calibration of the NMR instrumentation

5.2.2 Standard N,N-tetramethyl urea (TMU); standard TMU with a calibrated isotope ratio D/H.

COMPENDIUM OF INTERNATIONAL ANALYSIS OF METHODS - OIV
Determination of the deuterium distribution in ethanol by
SNIF-NMR

5.2.3 Other CRMs available used to check the distillation and preparation steps:

CRM		Parameter	Certified value	Uncertainty
CRM-656	Ethanol from wine, 96% vol.			
		t^D (ethanol) in % w/w	94.61	0.05
		$\delta^{13}C$ (ethanol) in ‰ VPDB	-26.91	0.07
		(D/H) _I (ethanol) in ppm	102.84	0.20
		(D/H) _{II} (ethanol) in ppm	132.07	0.30
		R (ethanol)	2.570	0.005
CRM-660	hydro alcoholic solution, 12% vol.			
		t^Q (ethanol) in % vol.	11.96	0.06
		$\delta^{13}C$ (ethanol) in ‰ VPDB	-26.72	0.09
		(D/H) _I (ethanol) in ppm	102.90	0.16
		(D/H) _{II} (ethanol) in ppm	131.95	0.23
		R	2.567	0.005
		(D/H) _w (water) in ppm	148.68	0.14

5.3 Apparatus

5.3.1 NMR spectrometer fitted with a specific 'deuterium' probe tuned to the characteristic frequency ν_0 of the field B_0 (e.g. for $B_0 = 7.05$ T, $\nu_0 = 46.05$ MHz and for $B_0 = 9.4$ T, $\nu_0 = 61.4$ MHz) having a

proton decoupling channel (B2) and field-frequency stabilization channel (lock) at the fluorine frequency. The NMR instrument can possibly be equipped with an automatic sample changer and additional data-processing software for the evaluation of the spectra and computation of the results. The performance of the NMR spectrometer can be checked using the Certified Reference Materials (sealed tubes CRM 123).

5.3.2 10 mm NMR sample tubes

5.3.3 Distillation apparatus

Note: Any method for ethanol extraction can be used as long as the alcohol in the wine is recovered without isotopic fractionation.

The Cadiot column shown in figure 1 is an example of a manual distillation system that allows to extract 96 to 98.5% of the ethanol of a wine without isotopic fractionation and obtain a distillate with an alcohol grade of 92 to 93 in % w/w (95% vol.).

Such a system is composed of:

- Electric heating mantle with voltage regulator,
- One-liter round-bottom flask with ground glass neck joint,
- Cadiot column with rotating band (moving part in Teflon),
- conical flasks with ground glass neck joints, for collection of the distillate

Automatic distillation systems are also available.

The performance of the distillation system may be checked periodically for both the yield of extraction as well as for accuracy for the isotopic determination. This control can be done by distillation and measurement of CRM -660.

5.3.4 The following common laboratory equipment and consumables is needed:

- micropipette with appropriate tips,
- balance with 0.1 mg accuracy or better,
- balance with 0.1g accuracy or better
- single use syringe for transfer of liquids,
- precise graduated flasks (50ml, 100 ml, 250ml, ...)
- flasks equipped with airtight closing systems and inert septa (for storage of aliquots of wines, distillates and residues until measurement)

-equipment and consumables as specified in the other methods referred to herein.

The laboratory equipment and consumables indicated in the above lists are examples and may be replaced by other equipment of equivalent performance.

6. Sampling (Preparation of the sample)

6.1 If not yet available, determine the alcoholic strength of the wine or of the fermented product (tv) to better than the nearest 0.05 % vol. (eg. using the OIV method MA-F-AS312-01-TALVOL).

6.2 Extraction of the ethanol

Using the appropriate graduated flask, introduce a homogeneous sample of a suitable volume V ml of the wine or the fermented product into the round-bottom flask of the distillation apparatus. Place a ground conical flask to receive the distillate. Heat the product to be distilled to obtain a constant reflux ratio at the level of the condenser. Start the collection of the distillate when a stable temperature of the vapours typical of the ethanol-water azeotrope (78 °C) is reached and stop the collection when the temperature increases. The collection of distillate should be continued until the ethanol-water azeotrope is completely recovered.

When using manually a Cadiot column (Figure 1) the following procedure can be applied:

-Collect the boiling liquid corresponding to the ethanol-water azeotrope, when the temperature increases, discontinue collection for five minutes. When the temperature returns to 78 °C, recommence collecting the distillate until the temperature of the vapours increases again. Repeat this operation until the temperature, after discontinuing collection, does not return to 78 °C.

Alternatively, commercially available distillation systems can be used.

The weight m^D of distillate collected is weighed to better than 0.1g.

In order to avoid isotopic fractionation, the distillate should be kept in a tight vial preventing any evaporation until further use for determination of the alcoholic strength (6.3) and preparation of the NMR tube (7.1).

An aliquot of a few ml of the residues is kept. Its isotope ratio $(D/H)_w^Q$ may be determined if required.

6.3 Determination of the alcoholic strength of the distillate

The alcoholic strength (%w/w) of the distillate must be determined with a precision better than 0.1%.

The water content of the distillate (ρ' g) can be determined by the Karl Fischer method using a sample of about 0.5 ml of alcohol of exactly known mass ρ g. The alcohol strength by mass of the distillate is then given by:

$$t_m^D \% \text{ w/w} = 100 (1 - \rho') / \rho$$

Alternatively the alcoholic strength can be determined by densimetry for instance using an electronic densimeter.

6.4 Yield of distillation

The yield of distillation is estimated using the following formula:

$$\text{Yield of dist. \%} = 100 t_m^D m^D / (V \cdot tv)$$

Given the uncertainty on each term and especially on tv , the yield of distillation is estimated at $\pm 0.5\%$ (in the case of a wine of 10% v/v).

When using the Cadiot column, no significant isotope fractionation effect is expected for yield of extraction higher than 96%. In any case the operator may use a sufficient volume V ml of wine or fermented product for the distillation to ensure that the yield of extraction is sufficient. Typically aliquots of 750, 500, 400 and 300 ml of wine sample should be sufficient to obtain a 96% yield when carrying out the above distillation procedure with the Cadiot column on wines or fermented products of respectively $tv = 4, 6, 8$ and 10% vol.

6.5 Fermentation of musts, concentrated musts and rectified concentrated musts

Prior to use, the yeast can be reactivated in a small volume of must. The fermentation vessel is equipped with a device to keep it airtight and to avoid loss of ethanol.

6.5.1 Musts

Place about one litre of must, whose concentration of fermentable sugars has been previously determined, in the fermentation vessel. Add about 1 g of dry yeast eventually reactivated beforehand. Insert device to keep it airtight. Allow fermentation to proceed until the sugar is used up. The fermented product can then be distilled following the procedure already described for wine in 6.1 to 6.4

Note: Musts preserved by addition of sulphur dioxide have to be desulphited by bubbling nitrogen through the must in a water bath at 70 to 80 °C under reflux in order to prevent isotope fractionation through evaporation of water. Alternatively, the sulphur dioxide can be removed by a small addition of a solution of hydrogen peroxide (H₂O₂).

6.5.2 Concentrated musts

Place V ml of concentrated must containing a known amount of sugar (approximately 170 g) into the fermentation vessel. Top up to one litre with (1000 - V) ml of water. Add dry yeasts (1 g) and 3 g of Bacto Yeast Nitrogen Base without amino acids. Homogenize and proceed as described in 6.5.1.

6.5.3 Grape sugar (Rectified concentrated musts)

Proceed as described in 6.5.2, topping up to one litre with (1000 - V) ml of water also containing 3 g of dissolved tartaric acid.

Note: Concentrated musts and rectified concentrated musts are diluted in local water having a (D/H) isotope concentration different of that of the original must. By convention, the (D/H)_I and (D/H)_{II} parameters measured on ethanol have to be normalised as if the must had fermented in water having the same deuterium concentration as V-SMOW (155.76 ppm).

This normalisation of the data is performed by using the following equations (Martin et al., 1996, J. AOAC, 79, 62-72):

$$\left(\frac{D}{H}\right)_I^{Norm.V-SMOW} = \left(\frac{D}{H}\right)_I - 0.19 \times \left[\left(\frac{D}{H}\right)_W^S - 155.76 \right]$$

$$\left(\frac{D}{H}\right)_{II}^{Norm.V-SMOW} = \left(\frac{D}{H}\right)_{II} - 0.78 \times \left[\left(\frac{D}{H}\right)_W^S - 155.76 \right]$$

where $\left(\frac{D}{H}\right)_W^S$ is the deuterium isotope ratio of the diluted must. This value can be computed using the equation of the Global Meteoric Water Line (Craig, 1961):

$$\left(\frac{D}{H}\right)_W^S = 155.76 \times \left[\frac{(8 \times \delta^{18}O + 10)}{1000} + 1 \right]$$

Where $\delta^{18}O$ is measured on the diluted must by the method for $^{18}O/^{16}O$ isotope ratio determination of water in wines and must [OIV-MA-AS2-12].

Retain 50 ml of sample of must or sulphur dioxide treated must or concentrated must or rectified concentrated must with a view to the possible extraction of the water and the determination of its isotope ratio $(D/H)_W^Q$.

7. Procedure

7.1 Preparation of alcohol sample for NMR measurement

- 10 mm diameter NMR probe: in a previously weighed bottle, collect 3.2 ml of distillate as described in section 6.2 and weigh it to the nearest 0.1 mg (m_A); then take 1.3 ml sample of the internal standard TMU (5.2.2) and weigh to the nearest 0.1 mg (m_{ST}).

Depending on the type of spectrometer and probe used, add a sufficient quantity of hexafluorobenzene (5.1.2) as a field-frequency stabilization substance (lock):

COMPENDIUM OF INTERNATIONAL ANALYSIS OF METHODS - OIV
Determination of the deuterium distribution in ethanol by
SNIF-NMR

Spectrometer	10 mm probe
7.05 T	150 μ l
9.4 T	35 μ l

These figures are indicative and the actual volume to be used should be adjusted to the sensitivity of the NMR instrument. While preparing the tube and until the NMR measurement, the operator should take care to avoid any evaporation of ethanol and TMU since this would cause isotopic fractionation, errors in the weights (m_A and m_{ST}) of the components and erroneous NMR results.

The correctness of the procedure of measurement including this preparation step can be checked using the CRM 656.

Note: the hexafluorobenzene can be added with 10% (v/v) of trifluoroacetic acid (5.1.3) in order to catalyze the fast hydrogen exchange on hydroxyle bond resulting in a single NMR peak for both the hydroxyle and residual water signals.

7.2 Recording of ^2H NMR spectra of the alcohol

The homogeneity of the magnetic field B_0 in the sample is optimized through the “shimming” procedure maximizing the ^{19}F NMR lock signal observed the hexafluorobenzene. Modern NMR spectrometers can perform automatically and efficiently this “shimming” procedure provided that the initial settings are close enough to the optimal magnetic field homogeneity for a given sample as is generally the case for a batch of ethanol samples prepared as described in 7.1. The efficiency of this procedure can be checked through the resolution measured on the spectrum obtained without exponential multiplication (i.e. $\text{LB} = 0$) (Figure 2b) and expressed by the half-width of the methyl and methylene signals of ethanol and the methyl signal of TMU, which must be less than 0.5 Hz in the best conditions. The sensitivity, measured with an exponential multiplying factor LB equal to 2 (Figure 2a) must be greater than or equal to 150 for the methyl signal of ethanol of alcoholic strength 95 % vol (93.5 % mas).

7.2.2 Checking the instrumental settings

Carry out customary standardization for homogeneity and sensitivity according to the manufacturer's specifications.

Use the sealed tubes CRM123 (H: High , M: Medium, L: Low).

Following the procedure described below in 9.3, determine the isotope values of these alcohols, denoting them H_{meas} , M_{meas} , L_{meas} .

Compare them with the given corresponding standard values, denoted by a superscript H_{st} , M_{st} , L_{st} .

Typically, as an indication the standard deviation obtained for 10 repetitions of each spectrum should be of the order of 0.01 for the ratio R and 0.5 ppm for $(D/H)_I$ and 1 ppm for $(D/H)_{II}$.

The average values obtained for the various isotopic parameters (R , $(D/H)_I$, $(D/H)_{II}$) must be within the corresponding standard deviation of repeatability given for those parameters for the CRM123. If they are not, carry out the checks again.

Once the settings have been optimized also other CRM materials can be used to monitor the quality of measurements in routine analysis.

7.3 Conditions for obtaining NMR spectra

Place a sample of alcohol prepared as in 7.1 in a 10 mm tube and introduce it into the probe.

Suggested conditions for obtaining NMR spectra are as follows:

- a constant probe temperature, set to better less than $\pm 0.5^\circ\text{K}$ variation in the range 302 K to 306 K depending on the heating power generated by the decoupling;
- acquisition time of at least 6.8 s for 1200 Hz spectral width (16K memory) (i.e. about 20 ppm at 61.4 MHz or 27 ppm at 46.1 MHz);
- 90° pulse;
- parabolic detection: fix the offset 01 between the OD and CHD reference signals for ethanol and between the HOD and TMU reference signals for water;
- determine the value of the decoupling offset 02 from the proton spectrum measured by the decoupling coil on the same tube. Good decoupling is obtained when 02 is located in the middle of the frequency interval existing between the CH₃- and CH₂- groups. Use the wide band decoupling mode or

composite pulse sequences (eg. WALTZ16) to ensure homogeneous decoupling on the whole spectrum.

For each spectrum, carry out a number of accumulations NS sufficient to obtain the signal-to-noise ratio indicated as sensitivity in 7.2 and repeat NE times this set of NS accumulations. The values of NS depend on the types of spectrometer and probe used. Examples of the possible choices are:

Spectrometer	10 mm probe
7.05 T	NS = 304
9.4 T	NS = 200

The number of repetitions NE should be statistically meaningful and sufficient to achieve the performance and precision of the method as reported below in §9.

In the case that two NMR sample tubes have been prepared following the procedure described in 7.1, five repetitions of NMR spectra (NE=5) can be recorded on each tube. The final result for each isotopic parameter corresponds to the mean value of the measurements obtained on the two NMR sample tubes. In that case, the acceptance criteria for validation of the results obtained with these two tubes are:

$$|\text{Mes1(D/H)}_I - \text{Mes2(D/H)}_I| < 0.5 \text{ ppm}, \quad |\text{Mes1(D/H)}_{II} - \text{Mes2(D/H)}_{II}| < 0.8 \text{ ppm}$$

8. Expression of results

For each of the NE spectra (see NMR spectrum for ethanol, Figure 2a), determine:

$$R = 3 \cdot \frac{h_{II}}{h_I} = 3 \cdot \frac{\text{height of signal II (CH}_3\text{ CH}_D\text{ OH)}}{\text{height of signal I (CH}_2\text{D CH}_2\text{ OH)}}$$

$$\left(\text{D/H}\right)_I = 1.5866 \cdot T_I \cdot \frac{m_{ST}}{m_A} \cdot \frac{\left(\text{D/H}\right)_{ST}}{t_m^D}$$

$$\left(\frac{D}{H}\right)_{II} = 2.3799 \cdot T_{II} \cdot \frac{m_{ST}}{m_A} \cdot \frac{\left(\frac{D}{H}\right)_{ST}}{t_m^D}$$

with

- $T_I = \frac{\text{height of signal I (CH}_2\text{D CH}_2\text{ OH)}}{\text{height of signal of internal standard (TMU)}}$
- $T_{II} = \frac{\text{height of signal II (CH}_3\text{ CHD OH)}}{\text{height of signal of internal standard (TMU)}}$

- m_{ST} and m_A , see 7.1

- t_m^D , see 6.3

- $\left(\frac{D}{H}\right)_{ST}$ = isotope ratio of internal standard (TMU) indicated on certificate delivered by IRMM.

The use of peak heights instead of peak area, which is less precise, supposes that peak width at half height is identical and is a reasonable approximation if applicable (Figure 2b).

For each of the isotope parameters, calculate the average and the confidence interval for the number of repeated spectra acquired on a given sample.

Optional softwares enable such calculations to be carried out on-line.

9. Precision

The repeatability and Reproducibility of the SNIF-NMR method has been studied through collaborative studies on fruit juices as reported in the bibliography here below. However these studies considered only the parameter $\left(\frac{D}{H}\right)_I$. In the case of wine data from in-house studies carried out by several laboratories can be considered for establishing the standard deviation of repeatability and the limit of repeatability as presented in Annex I. The results of proficiency testing reported in Annex II provide data that can be used to compute the standard deviation of Reproducibility and the limit of Reproducibility for wines.

COMPENDIUM OF INTERNATIONAL ANALYSIS OF METHODS - OIV
Determination of the deuterium distribution in ethanol by
SNIF-NMR

These figures can be summarised as follows:

	(D/H) _I	(D/H) _{II}	R
S _r	0.26	0.30	0.005
r	0.72	0.84	0.015
S _R	0.35	0.62	0.006
R	0.99	1.75	0.017

with

- S_r : standard deviation of repeatability
- r : limit of repeatability
- S_R: standard deviation of reproducibility
- R : limit of Reproducibility

REFERENCES

- MARTIN G.J., MARTIN M.L., MABON F., *Anal. Chem.*, 1982, 54, 2380-2382.
- MARTIN G.J., MARTIN M.L., *J. Chim. Phys.*, 1983, 80, 294-297.
- MARTIN G.J., GUILLOU C., NAULET N., BRUN S., Tep Y., Cabanis J.C.,
CABANIS M.T., SUDRAUD P., *Sci. Alim.*, 1986, 6, 385-405.
- MARTIN G.J., ZHANG B.L., NAULET N. and MARTIN M.L., *J. Amer. Chem. Soc.*, 1986, 108, 5116-5122.
- MARTIN G.J., GUILLOU C., MARTIN M.L., CABANIS M.T., TEP Y. et AERNY J., *J. Agric. Food Chem.*, 1988, 36, 316.
- MARTIN G. G., WOOD R., MARTIN, G. J., *J. AOAC Int.*, 1996 , 79 (4), 917-928.
- MARTIN G.G., HANOTE V., LEES M., MARTIN Y-L., *J. Assoc Off Anal Chem*, 1996, 79, 62-72
- CRAIG H., *Science* , 1961, 133,. 1702 - 1703

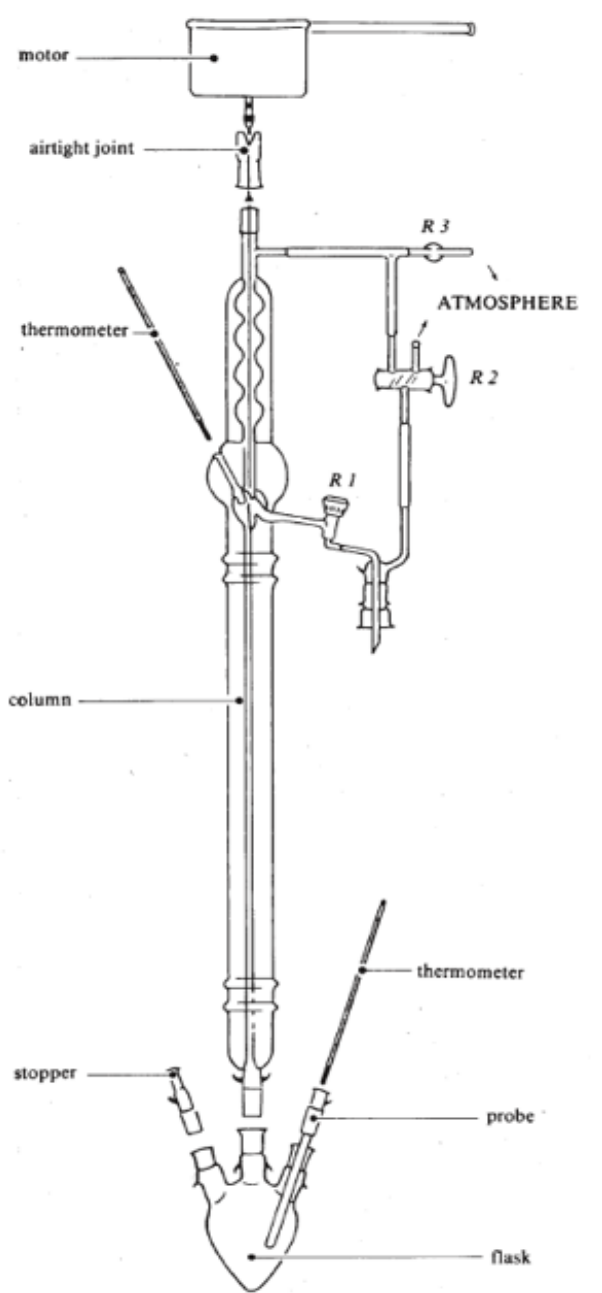

Figure 1 - Apparatus for extracting ethanol

COMPENDIUM OF INTERNATIONAL ANALYSIS OF METHODS - OIV
Determination of the deuterium distribution in ethanol by
SNIF-NMR

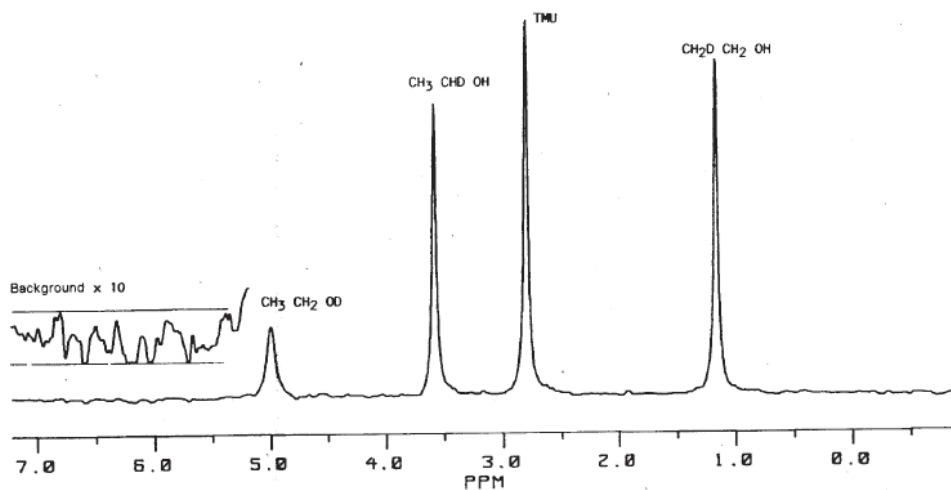

Figure 2a
 ^2H NMR spectrum of an ethanol from wine with an internal standard (TMU:
N, N-tetramethylurea)

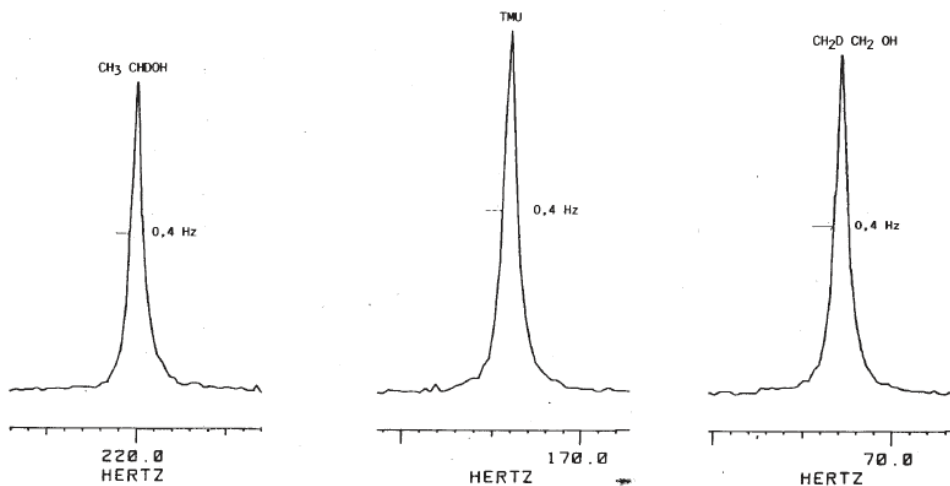

Figure 2b
 ^2H spectrum of ethanol taken under the same conditions as those of Figure
2a, but without exponential multiplication (LB = 0)

Annex I: Estimation of the repeatability from in-house repeatability studies

The in-house repeatability studies performed in 4 laboratories provide data that allows the estimation of the repeatability of the SNIF-NMR method.

These in-house repeatability studies have been performed by duplicate distillations and measurements of 10, 9 or 15 different wine samples by the laboratories 1, 2 and 3.

Alternatively the laboratory 4 performed 16 distillations and measurements on the same wine in condition of repeatability on a short period of time.

Table I-1: lab 1 : 10 wines analysed in duplicates

Sample	(D/H) _I	(D/H) _{II}	R	(D/H) _I abs (Δ(D/H) _I)	Squares	(D/H) _{II} abs (Δ(D/H) _{II})	Squares	R abs (Δ(R))	Squares
1	103.97	130.11	2.503	0.55	0.302	0.68	0.462	0.000	0.00000
	104.52	130.79	2.503						
2	103.53	130.89	2.529	0.41	0.168	0.32	0.102	0.016	0.00026
	103.94	130.57	2.513						
3	102.72	130.00	2.531	0.32	0.102	0.20	0.040	0.004	0.00002
	103.04	130.20	2.527						
4	105.38	132.39	2.513	0.14	0.020	0.20	0.040	0.000	0.00000
	105.52	132.59	2.513						
5	101.59	127.94	2.519	0.48	0.230	0.20	0.040	0.016	0.00026
	101.11	128.14	2.535						
6	103.23	132.14	2.560	0.30	0.090	0.36	0.130	0.001	0.00000

COMPENDIUM OF INTERNATIONAL ANALYSIS OF METHODS - OIV
Determination of the deuterium distribution in ethanol by
SNIF-NMR

	102.93	131.78	2.561						
7	103.68	130.95	2.526	0.15	0.023	0.75	0.563	0.011	0.00012
	103.53	130.20	2.515						
8	101.76	128.86	2.533	0.24	0.058	0.42	0.176	0.003	0.00001
	101.52	128.44	2.530						
9	103.05	129.59	2.515	0.04	0.002	0.44	0.194	0.007	0.00005
	103.01	129.15	2.508						
10	101.47	132.63	2.614	0.50	0.250	0.18	0.032	0.010	0.00010
	100.97	132.45	2.624						
				Sum of squares:	1.245		1.779		0.00081
				Sr	0.25		0.30		0.006
				r	0.71		0.84		0.018

COMPENDIUM OF INTERNATIONAL ANALYSIS OF METHODS - OIV
Determination of the deuterium distribution in ethanol by
SNIF-NMR

Table I-2: lab 2 : 9 wines analysed in duplicates

Sample	(D/H) _I	(D/H) _{II}	R	(D/H) _I	Squares	(D/H) _{II}	Squares	R	Squares
				abs (Δ(D/H) _I)		abs (Δ(D/H) _{II})		abs (Δ(R))	
1	105.02	133.78	2.548	0.26	0.068	0.10	0.010	0.008	0.00007
	104.76	133.88	2.556						
2	102.38	130.00	2.540	0.73	0.533	0.40	0.160	0.010	0.00011
	101.65	129.60	2.550						
3	100.26	126.08	2.515	0.84	0.706	0.64	0.410	0.008	0.00007
	99.42	125.44	2.523						
4	101.17	128.83	2.547	0.51	0.260	0.45	0.203	0.004	0.00002
	100.66	128.38	2.551						
5	101.47	128.78	2.538	0.00	0.000	0.26	0.068	0.005	0.00003
	101.47	128.52	2.533						
6	106.14	134.37	2.532	0.12	0.014	0.04	0.002	0.002	0.00000
	106.26	134.41	2.530						
7	103.62	130.55	2.520	0.05	0.003	0.11	0.012	0.003	0.00001
	103.57	130.66	2.523						
8	103.66	129.88	2.506	0.28	0.078	0.55	0.302	0.004	0.00001
	103.3	129.	2.50						
9	8	33	2		0.18		0.04		0.000
	103.5	129.	2.50						
	0	66	6	0.43	5	0.22	8	5	21
	103.9	129.	2.49						
	3	44	1						
				Sum of squares:	1.84 6		1.21 4		0.000 53
				Sr	0.32		0.26		0.005
				r	0.91		0.74		0.015

COMPENDIUM OF INTERNATIONAL ANALYSIS OF METHODS - OIV
Determination of the deuterium distribution in ethanol by
SNIF-NMR

Table I-3: lab 3 : 15 wines analysed in duplicates

Sample	(D/H) _I	(D/H) _{II}	R	(D/H) _I	Squares	(D/H) _{II}	Squares	R	Squares
				abs ($\Delta(D/H)_I$)		abs ($\Delta(D/H)_{II}$)		abs ($\Delta(R)$)	
1	101.63	125.87	2.477	0.06	0.004	0.46	0.212	0.007	0.00005
	101.57	125.41	2.470						
2	99.24	124.41	2.507	0.05	0.002	0.04	0.002	0.001	0.00000
	99.19	124.37	2.508						
3	101.23	125.07	2.471	0.06	0.004	0.16	0.026	0.005	0.00002
	101.17	125.23	2.476						
4	100.71	125.29	2.488	0.07	0.005	1.16	1.346	0.024	0.00058
	100.78	124.13	2.464						
5	99.89	124.02	2.483	0.18	0.032	0.56	0.314	0.007	0.00005
	99.71	123.46	2.476						
6	100.60	124.14	2.468	0.19	0.036	0.66	0.436	0.018	0.00032
	100.41	124.80	2.486						
7	101.47	125.60	2.476	0.23	0.053	0.14	0.020	0.003	0.00001
	101.70	125.74	2.473						
8	102.02	124.00	2.431	0.13	0.017	0.07	0.005	0.005	0.00002
	102.15	123.93	2.426						
9	99.69	124.60	2.500	0.40	0.160	0.53	0.281	0.000	0.00000
	100.09	125.13	2.500						
10	99.17	123.71	2.495	0.30	0.090	0.19	0.036	0.004	0.00002
	99.47	123.90	2.491						
11	100.60	123.89	2.463	0.40	0.160	0.54	0.292	0.001	0.00000
	101.00	124.43	2.464						
12	99.38	124.88	2.513	0.33	0.109	0.55	0.302	0.002	0.00000
	99.05	124.33	2.511						
13	99.51	125.24	2.517	0.44	0.194	0.01	0.000	0.011	0.00012
	99.95	125.25	2.506						
15	101.34	124.68	2.460	0.43	0.185	0.41	0.168	0.002	0.00000
	101.77	125.09	2.458						
Sum of squares:					1.050		3.437		0.00120
				Sr	0.19		0.34		0.006
				r	0.53		0.96		0.018

COMPENDIUM OF INTERNATIONAL ANALYSIS OF METHODS - OIV
Determination of the deuterium distribution in ethanol by
SNIF-NMR

Table I-4

lab 4 : one wine analysed 16 times

Repetition	(D/H) _I	(D/H) _{II}	R		(D/H) _I	(D/H) _{II}	R
1	101.38	126.87	2.503	Variance:	0.0703	0.0840	0.000013
2	101.30	126.22	2.492				
3	100.98	125.86	2.493	Sr	0.27	0.29	0.004
4	100.94	126.00	2.497				
5	100.71	125.79	2.498	r	0.75	0.82	0.010
6	100.95	126.05	2.497				
7	101.17	126.30	2.497				
8	101.22	126.22	2.494				
9	100.99	125.91	2.494				
10	101.29	126.24	2.493				
11	100.78	126.07	2.502				
12	100.65	125.65	2.497				
13	101.01	126.17	2.498				
14	100.89	126.05	2.499				
15	101.66	126.52	2.489				
16	100.98	126.11	2.498				

The pooled data for the standard deviation of repeatability and for the limit of repeatability can thus be estimated as:

	(D/H) _I	(D/H) _{II}	R
Sr	0.26	0.30	0.005
limit of repeatability r	0.72	0.84	0.015

Data of in-house repeatability studies were provided by (in alphabetic order):

-Bundesinstitut für Risikobewertung,
Thielallee 88-92 PF 330013 D-14195 BERLIN – GERMANY

-Fondazione E. Mach-Istituto Agrario di San Michele all'Adige,
Via E. Mach, 1 - 38010 San Michele all'Adige (TN), ITALY

-Joint Research Centre - Institute for Health and Consumer Protection,
I-21020 ISPRA (VA) – ITALY

-Laboratorio Arbitral Agroalimentario, Carretera de la Coruña, km 10,7
E-28023 MADRID –SPAIN

Annex II: Evaluation of the Reproducibility from proficiency testing data

Since December 1994 international proficiency testing exercises on the determination of isotopic parameters on wine and various other food matrices have been regularly organised. These proficiency testing exercises allow participating laboratories to assess their performance and the quality of their analyses. The statistical exploitation of these results obtained on a large number of samples over a long period of time allows the appreciation of the variability of the measurements under conditions of reproductibility. This enables a good estimation of the variance parameters and of the reproducibility limit of the method. The results of 40 rounds of proficiency testing since 1994 until 2010 for various type of wine (red, white, rosé, dry, sweet and sparkling) are summarised in the table II-1 here below.

For $(D/H)_I$ and $(D/H)_{II}$ the pooled S_R can thus be calculated using the following equation:

$$\sqrt{\frac{\sum_i^K (N_i - 1) S_{R,i}^2}{\sum_i^K (N_i - 1)}}$$

with N_i , and $S_{R,i}$ the number of values and the standard deviation of reproducibility of the i^{th} round, and K the number of rounds.

COMPENDIUM OF INTERNATIONAL ANALYSIS OF METHODS - OIV
Determination of the deuterium distribution in ethanol by
SNIF-NMR

Considering the definition of the intramolecular ratio R, and applying the standard error propagation rules assuming that $(D/H)_I$ and $(D/H)_{II}$ are uncorrelated (the covariance terms are then zero), one can also estimate the standard deviation of Reproducibility for this parameter.

The following figures can thus be calculated:

	$(D/H)_I$	$(D/H)_{II}$	R
S_R :	0.35	0.62	0.006
Limit of Reproducibility R	0.99	1.75	0.01

Table II-1 : FIT Proficiency Testing – Summary of statistical values observed on wine samples:

Sample	Year	Round	$(D/H)_I$			$(D/H)_{II}$		
			N	Mean	S_R	N	Mean	S_R
Red wine	1994	R1	10	102.50	0.362	10	130.72	0.33
Rosé wine	1995	R1	10	102.27	0.333	10	128.61	0.35
Red wine	1995	R2	11	101.45	0.389	11	127.00	0.55
Red wine	1996	R1	11	101.57	0.289	11	132.23	0.34
Rosé wine	1996	R2	12	102.81	0.322	12	128.20	0.60
White wine	1996	R3	15	103.42	0.362	15	127.97	0.51
Red wine	1996	R4	15	102.02	0.377	13	131.28	0.30
Rosé wine	1997	R1	16	103.36	0.247	16	126.33	0.44
White wine	1997	R2	16	103.42	0.444	15	127.96	0.53
Sweet White Wine	1997	R2	14	99.16	0.419	15	130.02	0.88
Wine	1997	R3	13	101.87	0.258	15	132.03	0.61
Sweet Wine	1997	R3	12	102.66	0.214	12	128.48	0.48
Rosé wine	1997	R4	16	102.29	0.324	16	129.29	0.63
Sweet Wine	1997	R4	15	102.04	0.269	13	131.27	0.30
White wine	1998	R1	16	105.15	0.302	16	127.59	0.59

COMPENDIUM OF INTERNATIONAL ANALYSIS OF METHODS - OIV
Determination of the deuterium distribution in ethanol by
SNIF-NMR

Sweet Wine	1998	R3	16	102.17	0.326	16	129.60	0.56
Red wine	1998	R4	17	102.44	0.306	17	131.60	0.47
White wine	1999	R1	14	102.93	0.404	13	129.64	0.46
Sweet Wine	2000	R2	15	103.19	0.315	14	129.43	0.60
Wine	2001	R1	12	105.28	0.264	16	131.32	0.68
Sweet Wine	2001	R2	14	101.96	0.249	15	128.99	1.05
Wine	2002	R1	17	101.01	0.365	16	129.02	0.74
Wine	2002	R2	17	101.30	0.531	17	129.28	0.93
Wine	2003	R1	18	100.08	0.335	18	128.98	0.77
Sweet Wine	2003	R2	17	100.51	0.399	18	128.31	0.80
Wine	2004	R1	18	102.88	0.485	19	128.06	0.81
Sweet Wine	2004	R3	16	101.47	0.423	16	130.10	0.71
Wine	2005	R1	19	101.33	0.447	19	129.88	0.76
Sweet wine	2005	R2	15	102.53	0.395	15	131.36	0.38
Dry wine	2006	R1	18	101.55	0.348	18	131.30	0.51
Sweet wine	2006	R2	18	100.31	0.299	18	127.79	0.55
Wine	2007	R1	18	103.36	0.403	18	130.90	0.90
Sweet wine	2007	R2	19	102.78	0.437	19	130.72	0.55
Wine	2008	R1	24	103.20	0.261	23	131.29	0.59
Sweet wine	2008	R2	20	101.79	0.265	19	129.73	0.34
Dry wine	2009	R1	24	102.96	0.280	23	130.25	0.49
Sweet wine	2009	R2	21	101.31	0.310	21	127.07	0.50
Dry wine	2010	R1	21	101.80	0.350	20	129.65	0.40
Sparkling wine	2010	R1	11	101.51	0.310	11	129.09	0.68
Dry wine	2010	R2	20	104.05	0.290	19	133.31	0.58